

AXLE SUSPENSION LOCKS RH

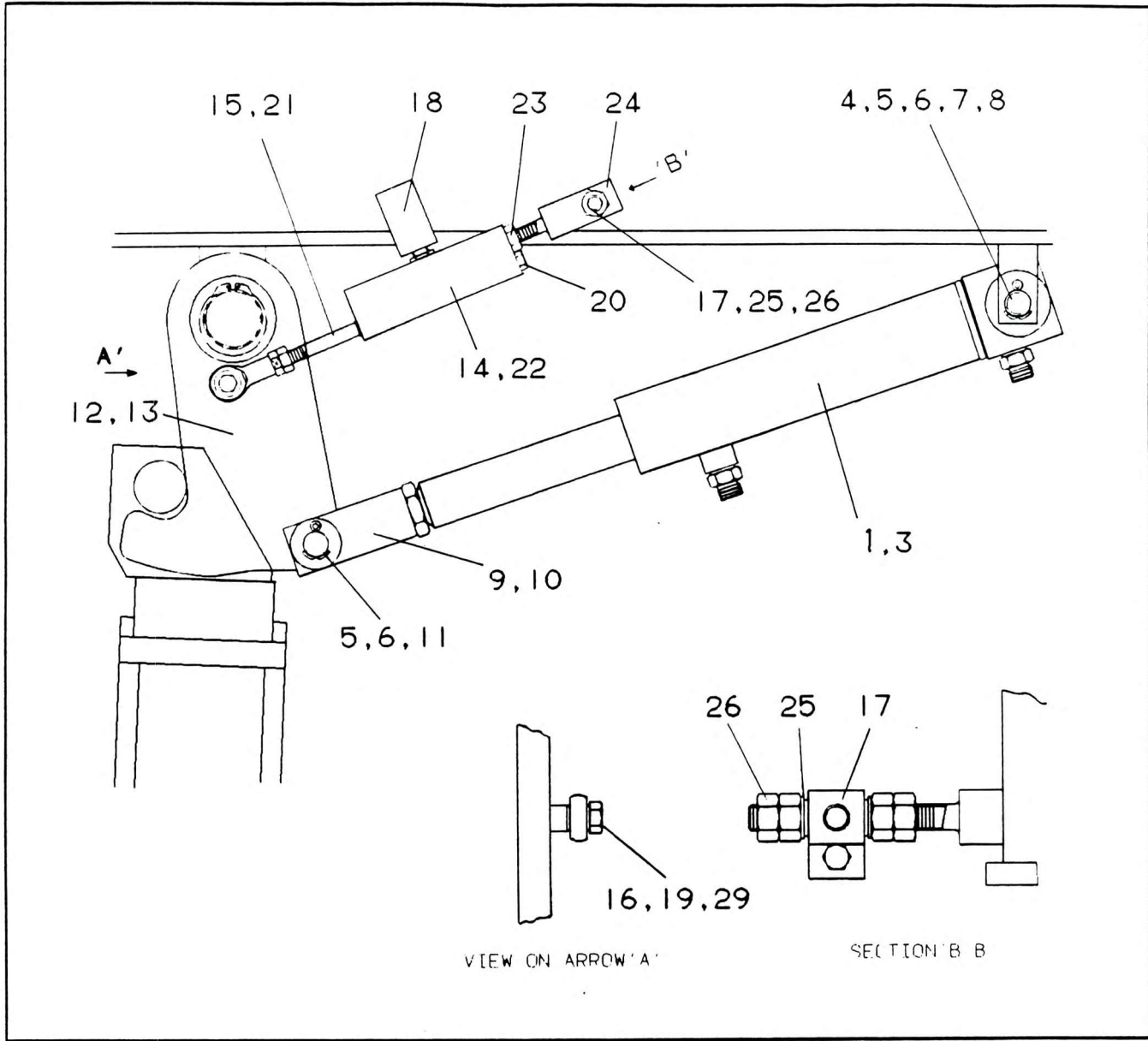

| NO. | PART NO.     | QTY. | DESCRIPTION                                 | NO.                                   | PART NO.     | QTY. | DESCRIPTION                |
|-----|--------------|------|---|---------------------------------------|--------------|------|----------------------------|
| 1 + | 6-372-004389 | 1    | Cylinder                                    | 17                                    | 6-910-990963 | 1    | Spacer                     |
| 3   | 7-447-060601 | 2    | Adaptor $\frac{3}{8}$ " BSP/ORFS            | 18                                    | 7-872-990273 | 1    | Limit Switch               |
| 4   | 6-689-990338 | 1    | Pin Suspension<br>Pivot                     | 19                                    | 7-069-990089 | 1    | Bearing Rod End            |
| 5   | 7-690-102010 | 2    | Split Pin 5/16" x<br>1 $\frac{1}{4}$ " Long | 20                                    | 13149        | 1    | Plug Drain $\frac{1}{4}$ " |
| 6   | 7066619      | 2    | Washer 20m                                  | 21                                    | 7-661-190003 | 1    | Nut M10                    |
| 7   | 7069601      | 1    | Nut M20                                     | 22                                    | 7-753-990031 | 1    | Wiper Ring                 |
| 8   | 7067310      | 1    | Washer Spring M20                           | 23                                    | 7-661-190003 | 1    | Nut M10                    |
| 9   | 8867620      | 1    | Clevis                                      | 24                                    | 6-689-990365 | 1    | Pin Block                  |
| 10  | 7069703      | 1    | Nut M24                                     | 25                                    | 7-951-290014 | 2    | Washer                     |
| 11  | 292566       | 1    | Pin   | 26                                    | 7-661-121003 | 4    | Nut                        |
| 12  | 6-966-990274 | 1    | Link Weld - Axle<br>Lock RH                 | 29                                    | 7-126-191553 | 1    | Screw M10 x 40<br>Long     |
| 13  | 7082123      | 1    | Circlip Ext. 45 Nom.                        | + See further breakdown in this group |              |      |                            |
| 14  | 6-086-990307 | 1    | Block - Switch                              |                                       |              |      |                            |
| 15  | 6-768-990159 | 1    | Rod - Axle Stop                             |                                       |              |      | 6-585-990048               |
| 16  | 6-910-990928 | 1    | Spacer                                      |                                       |              |      | Issue No. 01               |